



Ecocirc+ 20-18

Table of Contents

1 Introduction and Safety	3
1.1 Introduction.....	3
1.2 Safety terminology and symbols.....	3
1.3 User safety.....	4
1.4 Protecting the environment.....	5
1.5 Spare parts.....	5
2 Transportation and Storage	6
2.1 Examine the delivery.....	6
2.1.1 Examine the package.....	6
2.1.2 Examine the unit.....	6
2.2 Storage guidelines.....	6
3 Product Description	7
3.1 Product design.....	7
3.2 Features and functions.....	7
3.2.1 Operating modes.....	7
3.2.2 My ecocirc application.....	8
3.3 Parts.....	8
3.4 Data plate.....	9
4 Installation	10
4.1 Mechanical installation.....	10
4.1.1 Precautions.....	10
4.1.2 Requirements	11
4.1.3 Install the pump.....	12
4.1.4 Rotate the motor body of the pump.....	13
4.1.5 Insulation housing.....	14
4.2 Electrical installation.....	15
4.2.1 Precautions.....	15
4.2.2 Requirements.....	17
4.2.3 Connect the pump to the power supply.....	17
4.2.4 I/O terminals.....	18
5 Operation	21
5.1 Precautions.....	21
5.2 Requirements.....	21
5.3 Start the pump.....	21
5.4 Operating modes.....	21
5.5 Set the night mode.....	23
5.6 Reset the error.....	23
5.7 Connect a mobile phone to the pump.....	23

- 6 Maintenance..... 25**
 - 6.1 Precautions..... 25
 - 6.2 Examine the pump..... 25

- 7 Troubleshooting.....26**
 - 7.1 Precautions..... 26
 - 7.2 Insufficient cooling or heating of the pump..... 26
 - 7.3 The pump does not start..... 26
 - 7.4 The pump does not start..... 28
 - 7.5 Loss of functionality in the pump..... 28
 - 7.6 Communication via Bluetooth[®]/MD wireless technology failure..... 28
 - 7.7 Noise from the system..... 29
 - 7.8 Noise from the pump..... 29

- 8 Technical Specification.....31**
 - 8.1 Environmental requirements..... 31
 - 8.2 Torque specification..... 31
 - 8.3 Minimum suction pressure..... 31
 - 8.4 Electrical data..... 31
 - 8.4.1 I/O device..... 31
 - 8.5 Pumped liquid..... 31
 - 8.6 Maximum operating pressure..... 32
 - 8.7 Sound pressure..... 32
 - 8.8 Radio data..... 32

- 9 Product Warranty..... 33**

- 10 Certifications.....36**
 - 10.1 FCC 15.247..... 36
 - 10.2 RSS 102 and RSS-247..... 36

1 Introduction and Safety

1.1 Introduction

Purpose of the manual

The purpose of this manual is to provide the necessary information for working with the unit. Read this manual carefully before starting work.

Read and keep the manual

Save this manual for future reference, and keep it readily available at the location of the unit.

Intended use



WARNING:

Operating, installing, or maintaining the unit in any way that is not covered in this manual could cause death, serious personal injury, or damage to the equipment and the surroundings. This includes any modification to the equipment or use of parts not provided by Xylem. If there is a question regarding the intended use of the equipment, please contact a Xylem representative before proceeding.



WARNING: Risk Of Electric Shock

This Pump Has Not Been Investigated For Use In Swimming Pool Or Marine Areas.



CAUTION:

The ULus listed pumps are tested and evaluated with water only.

Other manuals

See also the safety requirements and information in the original manufacturer's manuals for any other equipment furnished separately for use in this system.



1.2 Safety terminology and symbols

About safety messages

It is extremely important that you read, understand, and follow the safety messages and regulations carefully before handling the product. They are published to help prevent these hazards:



- Personal accidents and health problems
- Damage to the product and its surroundings
- Product malfunction

Hazard levels

Hazard level		Indication
	DANGER:	A hazardous situation which, if not avoided, will result in death or serious injury
	WARNING:	A hazardous situation which, if not avoided, could result in death or serious injury
	CAUTION:	A hazardous situation which, if not avoided, could result in minor or moderate injury
NOTICE:		Notices are used when there is a risk of equipment damage or decreased performance, but not personal injury.

Special symbols

Some hazard categories have specific symbols, as shown in the following table.

Electrical hazard		Magnetic fields hazard	
	Electrical Hazard:		CAUTION:

1.3 User safety

All regulations, codes, and health and safety directives must be observed.

The site

- Observe lockout/tagout procedures before starting work on the product, such as transportation, installation, maintenance, or service.
- Pay attention to the risks presented by gas and vapors in the work area.
- Always be aware of the area surrounding the equipment, and any hazards posed by the site or nearby equipment.

Qualified personnel

This product must be installed, operated, and maintained by qualified personnel only.

Protective equipment and safety devices

- Use personal protective equipment as needed. Examples of personal protective equipment include, but are not limited to, hard hats, safety goggles, protective gloves and shoes, and breathing equipment.
- Make sure that all safety features on the product are functioning and in use at all times when the unit is being operated.

1.4 Protecting the environment

Emissions and waste disposal

Observe the local regulations and codes regarding:

- Reporting of emissions to the appropriate authorities
- Sorting, recycling, and disposal of solid or liquid waste
- Clean-up of spills

Exceptional sites



CAUTION: Radiation Hazard

Do NOT send the product to Xylem if it has been exposed to nuclear radiation, unless Xylem has been informed and appropriate actions have been agreed upon.

1.5 Spare parts



CAUTION:

Only use the manufacturer's original spare parts to replace any worn or faulty components. The use of unsuitable spare parts may cause malfunctions, damage, and injuries as well as void the warranty.

2 Transportation and Storage

2.1 Examine the delivery

2.1.1 Examine the package

1. Examine the package for damaged or missing items upon delivery.
2. Record any damaged or missing items on the receipt and freight bill.
3. If anything is out of order, then file a claim with the shipping company.

If the product has been picked up at a distributor, make a claim directly to the distributor.

2.1.2 Examine the unit

1. Remove packing materials from the product.
Dispose of all packing materials in accordance with local regulations.
2. To determine whether any parts have been damaged or are missing, examine the product.
3. If applicable, unfasten the product by removing any screws, bolts, or straps.
Use care around nails and straps.
4. If there is any issue, then contact a sales representative.

2.2 Storage guidelines

Storage location

The product must be stored in a covered and dry location free from heat, dirt, and vibrations.

NOTICE:

Protect the product against humidity, heat sources, and mechanical damage.

NOTICE:

Do not place heavy weights on the packed product.

3 Product Description

3.1 Product design

Usage

Ecocirc+ 20-18 is a wet rotor pump that uses permanent magnet and synchronous motor technology.

The pump is used for systems with variable flow rates to optimize the pump operation and decrease energy consumption.

Applications

- Potable water system with a stainless steel body
- Heating for hot water
- Cooling for cold water
- Solar water heating
- Geothermal energy

3.2 Features and functions

- Has electronic control
- Energy-efficient
- Has built-in electrical overload and dry-run protection to keep the pump safe
- Uses the Bluetooth^{®/MD 1} wireless technology to communicate

Software

The following features in the software protect the pump and motor:

- Anti-lock functionality
- Generator mode management
- Overtemperature
- Overvoltage and overcurrent
- Motor overload
- Motor fault

3.2.1 Operating modes

- Standby
- Constant pressure with three curves
- Proportional pressure with three curves
- Fixed speed with three curves
- Air purge
- Night setback
- eAdapt
- Bluetooth^{®/MD} Low Energy 5.0 wireless technology to communicate with mobile phone application

¹ The Bluetooth[®] word mark and logos are registered trademarks owned by Bluetooth SIG, Inc. and any use of such marks by Xylem Service Italia S.r.l. is under license.

- Single temperature heating or cooling setpoint
- External temperature sensor compatibility
- External 0-10 VDC voltage
- Working log history

3.2.2 My ecocirc application

This application is used to interact with the pump with the following functions:

- Extracts data during installation and maintenance
- Gets technical information and supporting documentation
- Generates work reports
- Identifies an applicable model for a specific system
- Allows the activation of temperature control modes and 0-10 V control mode

The application is available for iOS[®] and Android[™] mobile devices².

3.3 Parts

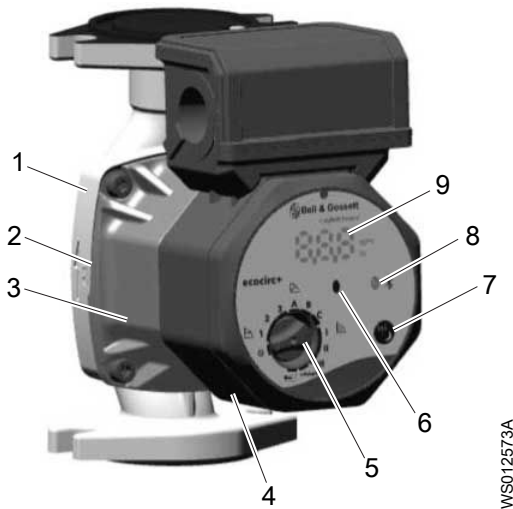

1. Pump body
2. Condensation drain
3. Motor body
4. Electric drive system
5. Selector
6. LED status indicator
7. Night mode button
8. LED wireless communication indicator
9. Digital display

² iOS[®] is a registered trademark of Cisco Systems, Inc. and/or its affiliates in the United States and certain other countries, used under license by Apple Inc.. Android is a trademark of Google LLC.

3.4 Data plate

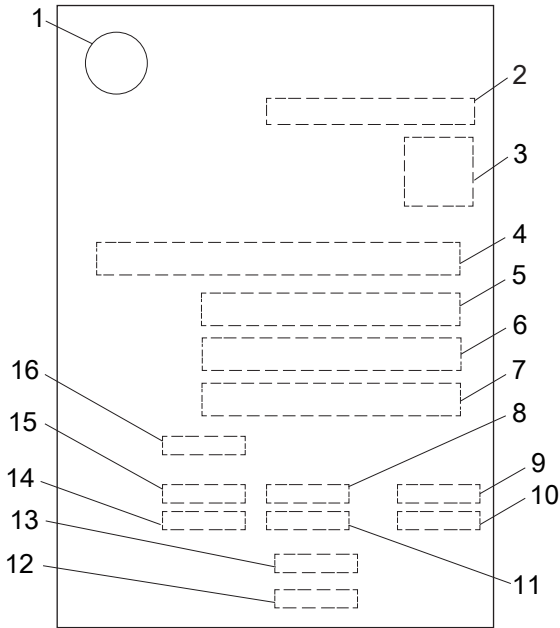

WS012667A

1. UL listing mark
2. UL control number
3. QR code
4. Product name
5. Product code
6. Serial number
7. Date
8. Minimum input power
9. Degree of protection
10. Enclosure type
11. Maximum input power
12. Maximum operating pressure
13. Maximum liquid operating temperature
14. Maximum input current
15. Minimum input current
16. Input voltage range

Identification code

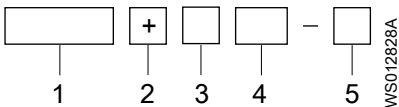

WS012828A

1. Series name
2. Display present or not present
3. Maximum head, feet
4. Maximum flow, gallons (US) per minute
5. Pump body, cast iron or stainless steel

4 Installation

4.1 Mechanical installation

4.1.1 Precautions

Before starting work, make sure that the safety instructions in the chapter [Introduction and Safety](#) on page 3 have been read and understood.



WARNING:

Do not operate the unit in an area where explosive gases are present.



WARNING:

The heating of water and other fluids causes volumetric expansion. The associated forces can cause the failure of system components and the release of high-temperature fluids. In order to prevent this, install properly sized and located compression tanks and pressure-relief valves. Failure to follow these instructions can result in serious personal injury or death, or property damage.



WARNING:

California Proposition 65 warning! This product contains chemicals known to the state of California to cause cancer and birth defects or other reproductive harm.



WARNING:

Do not install this pump in submersible locations. This is a non-submersible pump.



WARNING:

Do not install this pump in outdoor locations. This is an indoor use only pump.



DANGER: Do not install this pump in swimming pools or marine areas. Failure to follow these instructions could result in serious personal injury, death and/or property damage.

**CAUTION:**

CAUTION: PROPERTY DAMAGE HAZARD. It is not advisable to install circulators in an attic or upper floor over finished living space. If the circulator must be installed over head, or over expensive equipment, provide adequate drainage in the event of leakage. Failure to follow these instructions could result in property damage.

**CAUTION:**

Read this manual carefully before installing and using the product. Improper use of the product can cause personal injury and damage to property, and may void the warranty.

**CAUTION:**

The operator must be aware of safety precautions to prevent physical injury.

NOTICE:

Do not use this pump to handle liquids containing abrasive, solid or fibrous substances, toxic or corrosive liquids, potable liquids other than water or liquids not compatible with the pump construction material. Water pH must be maintained between 7-9 and water hardness must not exceed 14 grains/gallon, with suspended solids less than 100 PPM. An improper use of the product leads to the loss of the warranty.

4.1.2 Requirements

- The pump must not be installed at the lowest point in the system.
- The pump must not touch other pumps.
- The pipes must be supported independently to prevent them from weighing on the pump.
- Before the pipes are connected to the pump, they must be cleaned of unwanted material and welding residue.
- If a check valve is used, it must be installed in the discharge nozzle of the pump.

4.1.3 Install the pump

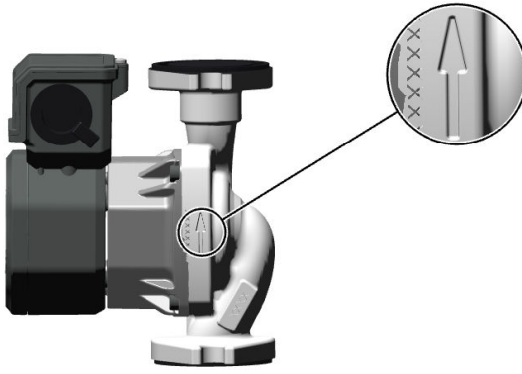
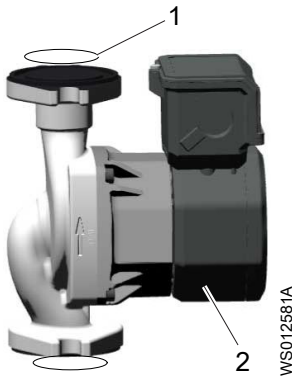

Figure 1: Correct direction of the liquid flow

1. Install the pump with new gaskets.
The gaskets must be between the pipe flanges.



1. Gasket
2. Pump

2. Install the pump in one of the following correct positions.

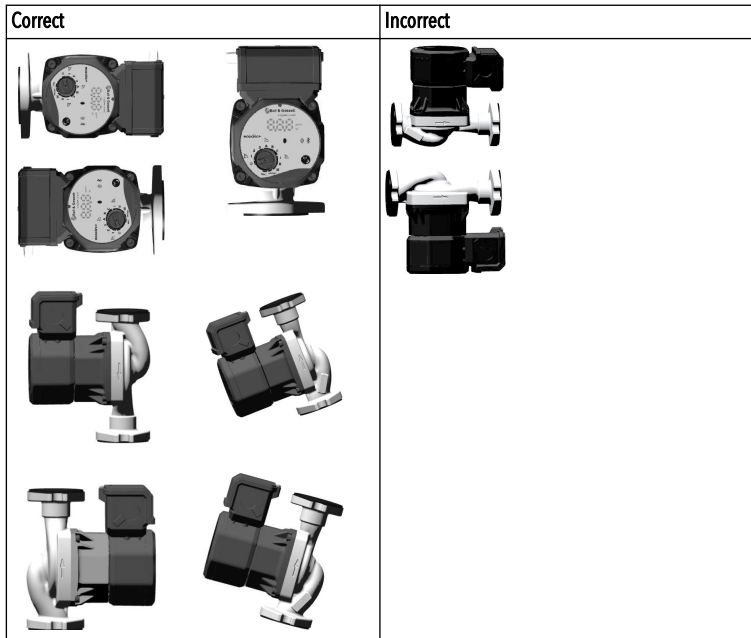

- Use a torque wrench to tighten the nuts on the companion flange fasteners.

Fasteners	Torque
Companion flange fasteners	13 Nm (115 lbf.in)
Union threaded ring nuts	See Torque specification on page 31

4.1.4 Rotate the motor body of the pump

The motor assembly of the pump can be rotated to $\pm 90^\circ$.

- Remove the screws from the pump body.

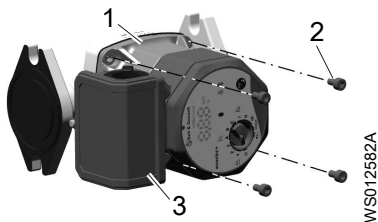

- Pump body
- Screw
- Junction box

- Rotate the pump housing.

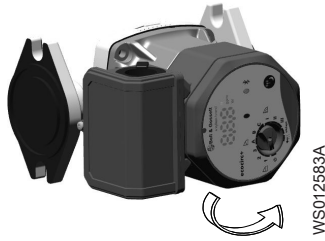

3. Install the junction box in one of the following correct positions.

Correct	Incorrect

4. Use a torque wrench to tighten the screws of the pump body.
The torque must be 5 Nm (44 lbf.in).



4.1.5 Insulation housing

4.1.5.1 Requirements

NOTICE:

Improper installations shown above can cause the pump to fail prematurely and create an electrical hazard and/or damage caused by water leakage.

- Only use the pump thermal shells that are included in the delivery. Do not insulate the motor housing, the electronics can overheat and cause the pump to thermally overload.
- The thermal shells that are included with the pump must only be used in hot water circulation applications with fluid temperature above 68°F (20°C). The thermal shells are permeable to water vapor.
- The pump housing must not be insulated past the motor flange. If the vapor barrier insulation is used for cold water applications, the flange drain path must remain open to allow for condensation to drain out of the motor housing.

4.1.5.2 Install the insulation housing

Install the insulation housing on the pump.

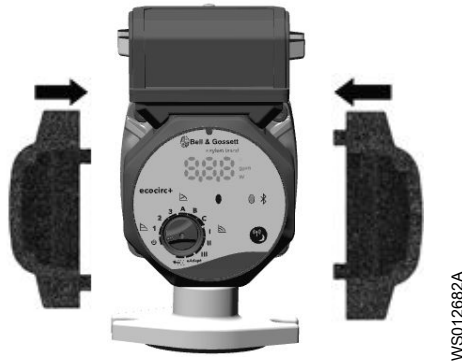

4.2 Electrical installation

4.2.1 Precautions

Before starting work, make sure that the safety instructions have been read and understood.



DANGER: Electrical Hazard

Before starting work on the unit, make sure that the unit and the control panel are isolated from the power supply and cannot be energized. This applies to the control circuit as well.



DANGER: Crush Hazard

Moving parts can entangle or crush. Always disconnect and lock out power before servicing to prevent unexpected startup. Failure to do so could result in death or serious injury.



WARNING: Electrical Hazard

Risk of electrical shock or burn. A certified electrician must supervise all electrical work. Comply with all local codes and regulations.



WARNING: Electrical Hazard

There is a risk of electrical shock or explosion if the electrical connections are not correctly carried out, or if there is fault or damage on the product. Visually inspect equipment for damaged cables, cracked casings or other signs of damage. Make sure that electrical connections have been correctly made.



WARNING:

To Reduce The Risk of Electric Shock, See Instruction Manual for Proper Installation



CAUTION: Electrical Hazard

Prevent cables from becoming sharply bent or damaged.

4.2.1.1 Grounding (earthing)

Grounding (earthing) must be done in compliance with all local codes and regulations.

If necessary, a grounded metal conduit must be used.



DANGER: Electrical Hazard

All electrical equipment must be grounded (earthed). Test the ground (earth) lead to verify that it is connected correctly and that the path to ground is continuous.



WARNING: Electrical Hazard

If the power cable is jerked loose, then the ground (earth) conductor must be the last conductor to come loose from its terminal. Make sure that the ground (earth) conductor is longer than the phase conductors at both ends of the cable.

4.2.2 Requirements

- The National Electrical Code (NEC), Canadian Electrical Code (CEC), and local codes must be followed.
- If the branch circuit is fitted with a ground fault circuit interrupter, it must be applicable to use with the inverter-driven appliances.
- The electrical cables must be protected from high temperature and vibration.
- The current type and voltage of the power supply connection must follow the specifications on the nameplate of the pump.
- The electrical wires must be 14 AWG or larger.
- The high-voltage wires and low-voltage wires must be routed in separate conduit.
- Before connecting the power supply wiring, check that the power supply is switched off.

4.2.3 Connect the pump to the power supply

1. Remove the screw from the cover of the terminal box.
2. Remove the cover from the terminal box.
3. Put the high-voltage wires through the conduit fitting.
The conduit fitting must be ½ in trade size (12.7 mm).
4. Connect the wires according to the wiring diagram by using the UL certified wire nut connectors.
 - a) If applicable, connect the ground wire.
 - b) If applicable, put all the low voltage wires through the separate conduit fitting.

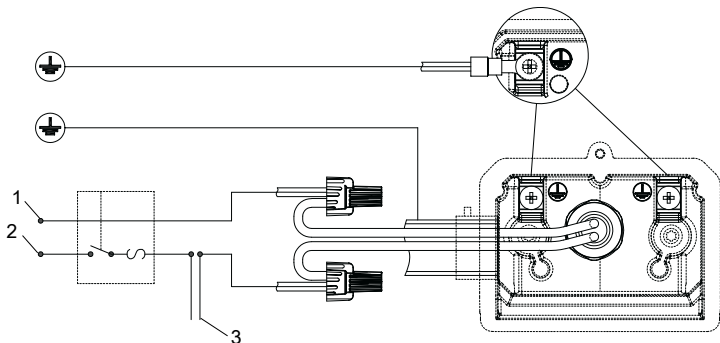

1. Neutral
2. Line
3. Remote control (If necessary)

5. Put the cover on the terminal box.
6. Tighten the screw of the cover.

4.2.4 I/O terminals

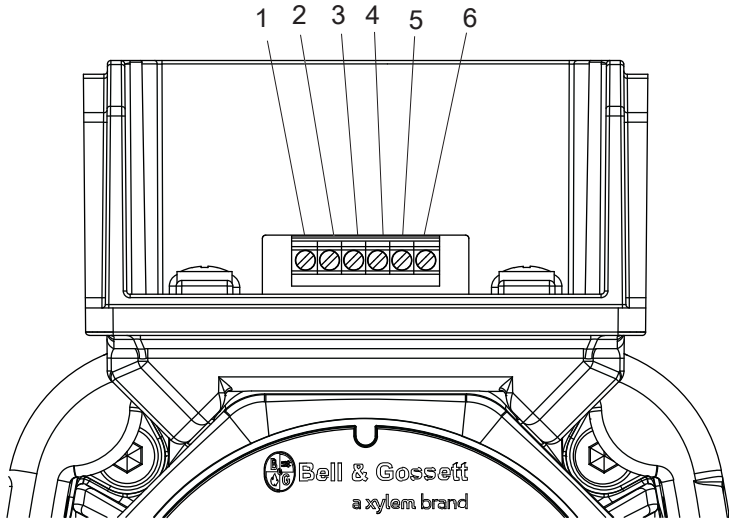

WS012687A

Terminal	Parameter	Description
1	Temp IN+	External temperature sensor input
2	Temp IN-	External temperature sensor input
3	0-10V IN+	0-10V constant speed input
4	0-10V IN-	0-10V constant speed reference
5	Not used	Not used
6	Not used	Not used

4.2.4.1 Control mode for water temperature

Control modes for water temperature can be activated only by using the application **MY ecocirc**.

Mode	Description
Constant absolute temperature, ConstT	Controls the speed of motor to maintain a constant water temperature in the system This mode uses the external temperature sensor for heating and cooling applications.

Mode	Description
Constant pressure that depends on the water temperature, $\text{Const}\Delta P/T$	<p>Changes the setpoint of the differential constant pressure according to the measured water temperature</p> <p>This mode is used in the following applications:</p> <ul style="list-style-type: none"> • Uses the external temperature sensor for positive relation, P/T • Uses the external temperature sensor for negative relation, P/T • Uses the external temperature sensor for positive relation, P/T • Uses the external temperature sensor for negative relation, P/T
Proportional pressure that depends on the water temperature	<p>Changes the setpoint of the differential proportional pressure according to the measured fluid temperature</p> <p>This mode is used in the following applications:</p> <ul style="list-style-type: none"> • Uses the external temperature sensor for positive relation, P/T • Uses the external temperature sensor for negative relation, P/T • Uses the external temperature sensor for positive relation, P/T • Uses the external temperature sensor for negative relation, P/T

Alarm code

When there is a fault in the temperature sensor, the following alarm code is shown in the user interface:

Sensor	Alarm code
Water temperature	A06

4.2.4.2 Control mode for analog voltage input

Analog Voltage input recognizes automatically the presence of a valid 0-10V signal (see thresholds, referred to pump status, on the table below).

Mode	Description
Rotational speed that the VDC input controls at terminals 3 and 4	<p>Uses the external control voltage input to control the speed of the pump</p> <p>The speed of the pump is maximum at 10 VDC and minimum at 1.5 VDC.</p> <p>For more information, see Pump status on page 20.</p>

Pump status

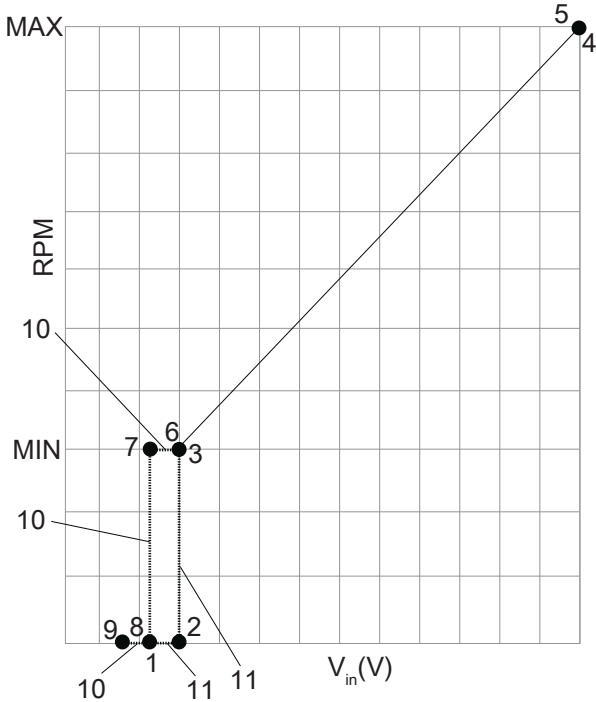

WS012769A

Position	Control voltage input (V_{in}), thresholds (V)	V_{in} , increases		V_{in} , decreases	
		Speed setpoint (rpm)	Pump status	Speed setpoint (rpm)	Pump status
1 and 7	1.20	0	OFF	MIN	RUN
2	1.49	0	OFF	MIN	RUN
3 and 6	1.50	MIN	RUN	MIN	RUN
4 and 5	10	MAX	RUN	MAX	RUN
8	1.19	-	Input is disabled	0	OFF
9	0.8	-	Input is disabled	0	OFF

Position	rpm
10	V_{in} , decreases
11	V_{in} , increases

5 Operation

5.1 Precautions

Before starting work, make sure that the safety instructions in the chapter [Introduction and Safety](#) on page 3 have been read and understood.



WARNING: Crush Hazard

Risk of automatic restart.



CAUTION:

Do not exceed the maximum working pressure of the pump. This information is listed on the nameplate of the pump.

5.2 Requirements

Before starting the pump, follow all the instructions in the chapter [Installation](#) on page 10.

The pump must be vented fully.

The minimum suction pressure for the pump must be set as given in the table [Minimum suction pressure](#) on page 31.

5.3 Start the pump

Turn on the power supply.



On the user interface, the blinking yellow light shows that the pump has started.

5.4 Operating modes

The user interface has the following operating modes:



Position	Operating mode	LED status	Description
	Standby	Blinks yellow	The pump is on standby

Position	Operating mode	LED status	Description
Performance curve: <ul style="list-style-type: none"> • 1. Low • 2. Intermediate • 3. High 	Operation at constant pressure	-	This position is selected for in-floor heating systems. The pressure stays constant, when the water flow is increased or decreased.
Performance curve: <ul style="list-style-type: none"> • A. Low • B. Intermediate • C. High 	Operation at proportional pressure	-	This position is selected for two-pipe heating systems. The pressure changes according to the actual demand for heat. The performance is selected according to the features of the system or heat demand.
Constant pump speed: <ul style="list-style-type: none"> • I. Low • II. Intermediate • III. High 	Operation at constant pump speed	-	This position is selected for one-pipe heating systems. The speed stays constant, when the water flow is increased or decreased. The speed is selected according to the features of the system or number of valves that can be opened at the same time.
eAdapt	eAdapt	Green	This position is selected to optimize the energy consumption by identifying the ideal duty point.
	Air purge	Blinks green	This position is selected to remove the dissolved gases from the pump. The air purge must be done for 3 minutes. If necessary, allow the air purge for more than 3 minutes according to the features of the system.
	Night	-	This position is selected to decrease the energy consumption of the pump, when the heating system is switched off. The pump returns to the original duty point when the system restarts and the water temperature increases. For more information, see Set the night mode on page 23.

5.5 Set the night mode

If the night mode is active when the power is off, it is deactivated when the power is turned on.

1. Select one of these operating modes 1, 2, 3, A, B, C, I, II, and III on the user interface.
2. Press and hold the night mode button to activate the night mode.
The yellow light shows that the night mode is on.
The green light shows that the night mode is off.



3. Press and hold the night mode button to deactivate the night mode.

5.6 Reset the error

1. Disconnect the power supply to the pump.
2. Wait for 1 minute.
3. Turn on the power supply.

5.7 Connect a mobile phone to the pump

The **MY ecocirc** application is installed in the mobile phone.

1. Open the **MY ecocirc** application on the mobile phone.
2. Turn on communication via Bluetooth® wireless technology in the mobile phone.
3. Press and hold the night mode button, on the user interface of the pump.
The LED light blinks shows that the pump is ready to connect.



4. Select the ecocirc+ from list of the devices that are detected in the device connectivity of the mobile phone.
5. Press and hold the night mode button on the user interface.
The digital display shows the three-digit personal identification number (PIN).
6. Note the three-digit PIN.
7. Repeat the steps 5 on page 24 and 6 on page 24 to obtain the last 3 digits of the PIN.
8. Enter the six-digit PIN number into the mobile phone.
The six-digit PIN number consists of two sets of three-digit numbers that are taken from the pump user interface.

6 Maintenance

6.1 Precautions

Before starting work, make sure that the safety instructions in the chapter [Introduction and Safety](#) on page 3 have been read and understood.



Electrical Hazard:

Disconnect and lock out electrical power before installing or servicing the unit.



WARNING:

- Always wear protective gloves when handling the pumps and motor. When pumping hot liquids, the pump and its parts may exceed 40°C (104°F).
 - Maintenance and service must be performed by skilled and qualified personnel only.
 - Observe accident prevention regulations in force.
-

6.2 Examine the pump

Visually examine the pump for leaks.

If there are leaks, the pump must be replaced.

7 Troubleshooting

7.1 Precautions

Before starting work, make sure that the safety instructions in the chapter [Introduction and Safety](#) on page 3 have been read and understood.



DANGER: Electrical Hazard

Troubleshooting a live control panel exposes personnel to hazardous voltages. Electrical troubleshooting must be done by a qualified electrician.



DANGER: Crush Hazard

Moving parts can entangle or crush. Always disconnect and lock out power before servicing to prevent unexpected startup. Failure to do so could result in death or serious injury.

7.2 Insufficient cooling or heating of the pump

LED status	Cause	Remedy
Green	The performance of the pump is low.	<ol style="list-style-type: none"> Do one of the following methods to start the pump: <ul style="list-style-type: none"> Increase the speed of the pump to increase the head Select another operating mode If the problem continues, replace the pump.
Yellow	The night mode is activated.	<ol style="list-style-type: none"> Deactivate the night mode. If the problem continues, replace the pump.
Blinks red	The dry run of the pump is detected.	<ol style="list-style-type: none"> Check that the pump does not contain air. Check that the liquid pressure of the pump is according to the working limits. Check that the pump is installed correctly. Start the air purge process. If the problem continues, replace the pump.

7.3 The pump does not start

The LED is on.

LED status	Error	Cause	Remedy
Blinks yellow	Off	The selector is set to the standby mode.	Select one of these operating modes 1, 2, 3, A, B, C, I, II and III.
Red	E02	The supply of current to the motor is too high.	<ol style="list-style-type: none"> Reset the error. For more information, see Reset the error on page 23. If the problem continues, replace the pump.

LED status	Error	Cause	Remedy
	E03	The supply voltage is too high.	<ol style="list-style-type: none"> 1. Check that the grid voltage is in accordance with the rated values. 2. Reset the error. For more information, see Reset the error on page 23. 3. If the problem continues, replace the pump.
	E03 or E06	The regeneration effect occurs because the other equipment generates the water flow.	<ol style="list-style-type: none"> 1. Remove the source of the flow. 2. Reset the error. For more information, see Reset the error on page 23. 3. If the problem continues, replace the pump.
	E04	<ul style="list-style-type: none"> • The motor is stalled. • The rotor is blocked or loss of speed. 	<ol style="list-style-type: none"> 1. The unit automatically carries out several high-torque startup attempts. 2. If the problem continues, do the following methods: <ul style="list-style-type: none"> - Check that the pumped liquid is in accordance with the working limits. - Clean the system. - Reset the error. For more information, see Reset the error on page 23. 3. If the problem continues, replace the pump.
	E05	The motor control shows error.	<ol style="list-style-type: none"> 1. Reset the error. For more information, see Reset the error on page 23. 2. If the problem continues, replace the pump.
	E06	The supply voltage is too low.	<ol style="list-style-type: none"> 1. Check that the grid voltage is in accordance with the rated values. 2. Reset the error. For more information, see Reset the error on page 23. 3. If the problem continues, replace the pump.
	E07	The motor is overload.	<ol style="list-style-type: none"> 1. Reset the error. For more information, see Reset the error on page 23. 2. Check that the pumped liquid is in accordance with the working limits. 3. If the problem continues, replace the pump.
	E08	The motor gets overheated.	<ol style="list-style-type: none"> 1. Reset the error. For more information, see Reset the error on page 23. 2. Check that the ambient and pumped liquid temperature is in accordance with the working limits. 3. Check that the unit is installed according to the instructions in the manual. 4. If the problem continues, replace the pump.
	E09	The electrical motor fails.	<ol style="list-style-type: none"> 1. Reset the error. For more information, see Reset the error on page 23. 2. If the problem continues, replace the pump.

LED status	Error	Cause	Remedy
	E10	The protection against dry run of motor	<ol style="list-style-type: none"> 1. Reset the error. For more information, see Reset the error on page 23. 2. If the problem continues, replace the pump.

7.4 The pump does not start

The LED and the user interface are switched off.

LED status	Error	Cause	Remedy
Off	None	The following electric safety devices are open: <ul style="list-style-type: none"> • System fuse • Circuit breaker of thermal magnetic device • Ground fault circuit interrupter 	<ol style="list-style-type: none"> 1. Reset the electric safety devices. 2. Replace the fuse for the pump. 3. Reset the ground fault circuit interrupter.
		The power supply is disconnected.	<ol style="list-style-type: none"> 1. Check that the connector is connected correctly to the pump. 2. Turn on the power supply.
		The wiring is incorrect.	Reset the electrical connections of the connector.
		The pump is defective.	Replace the pump.

7.5 Loss of functionality in the pump

LED status	Error	Cause	Remedy
Green	A11 or OFF	The communication of the printed circuit board fails.	<ol style="list-style-type: none"> 1. Reset the error. For more information, see Reset the error on page 23. 2. If the problem continues, replace the pump.

7.6 Communication via Bluetooth[®]/MD wireless technology failure

LED status		Error	Cause	Remedy
State	Wireless			
Green	Off	None	The night mode button fails.	<ol style="list-style-type: none"> 1. Reset the error. For more information, see Reset the error on page 23. 2. Press and hold the night mode button for more than 4 seconds. 3. If the problem continues, replace the pump.
Blinks green		Alr		
Blinks yellow		OFF		
Red		E01 to E10		
Blinks red		None	The wireless function module fails	

LED status		Error	Cause	Remedy
State	Wireless			
-	Blinks fast	-	The wireless function is not connected to the mobile device.	Connect the wireless function with the mobile device.
		-	The incorrect pairing of PIN the mobile device	<ol style="list-style-type: none"> 1. Generate a new PIN. 2. Connect the mobile device. 3. Reset the error. For more information, see Reset the error on page 23.
	Steady light	-	The communication error	<ol style="list-style-type: none"> 1. Reset the error. For more information, see Reset the error on page 23. <ol style="list-style-type: none"> 2. If the problem continues, replace the pump.

7.7 Noise from the system

LED status	Error	Cause	Remedy
Blinks green	Alr	The air purge is active.	<ol style="list-style-type: none"> 1. Select one of these operating modes 1, 2, 3, A, B, C, I, II, and III. 2. Wait for 3 minutes to complete the air purge process.
Green	None	The air in the system	<ol style="list-style-type: none"> 1. Release the air in the system. 2. Start the air purge process. 3. Wait for 3 minutes to complete the air purge process.
		The flow rate is too high. The turbulence is too high.	Do one of the following methods to start the pump: <ul style="list-style-type: none"> • Decrease the head speed of the pump to decrease the head • Select a different operating mode
		The following systems are blocked: <ul style="list-style-type: none"> • Piping • Air elimination • Valves 	Examine the systems.

7.8 Noise from the pump

LED status	Error	Cause	Remedy
Blinks green	Alr	The air purge is active.	<ol style="list-style-type: none"> 1. Select one of these operating modes 1, 2, 3, A, B, C, I, II, and III. 2. Wait for 3 minutes to complete the air purge process.

7 Troubleshooting

LED status	Error	Cause	Remedy
Green	None	Air in the pump	<ol style="list-style-type: none"> 1. Check that the pump is not installed at the highest point of the system. 2. Start the air purge process. 3. Wait for 3 minutes to complete the air purge process.
		Cavitation	<ol style="list-style-type: none"> 1. Do one of the following methods to decrease the cavitation: <ul style="list-style-type: none"> - Increase the system pressure according to the working limits. - Select a different operating mode. - Decrease the head speed of the pump to decrease the head 2. If the problem continues, replace the pump.
		Unwanted materials in the pump	<ol style="list-style-type: none"> 1. Clean the pump. 2. If the problem continues, replace the pump.

8 Technical Specification

8.1 Environmental requirements

Feature	Value
Operating environment	Non-aggressive, nonexplosive atmosphere, and no frost
Operating temperature	-10°C to 40°C (14°F to 104°F)
Relative humidity	< 95% at 40°C (104°F), non-condensing

8.2 Torque specification

Joint size	Pipe material	Torque, Nm (lbf.ft)
G1	Plastic	50 (37)
G1	Cast iron	85 (63)
G1¼	Cast iron	105 (78)
G1½	Cast iron	125 (92)
G2	Cast iron	165 (122)

8.3 Minimum suction pressure

Pressure, MPa (psi)	Head, m (ft)	Temperature, °C (°F)
0.005 (0.725)	0.5 (1.6)	50 (122)
0.03 (4.35)	3 (10)	95 (203)
0.1 (14.5)	10 (33)	110 (230)

8.4 Electrical data

Feature	Description
Power supply voltage	115 V ±10%, 50/60 Hz
Insulation class	155 F
Degree of protection	IP44

8.4.1 I/O device

Device	Description
Temperature sensor	1 kilohm at 25°C (77°F)

8.5 Pumped liquid

Feature	Description
Temperature	-10°C to 110°C (14°F to 230°F)
Concentration of glycol mixture	≤50%

The pump can be used with water/propylene glycol mixtures up to 50% with a maximum viscosity of 50cST at 14°F (-10°C). The pump has built-in overload and thermal protection to protect the pump from overload due to increased fluid viscosity. Pump performance is based on 77°F (25°C). Therefore pumping of glycol mixtures will affect max performance, depending on mixture concentration and temperature.

8.6 Maximum operating pressure

- 1 MPa (145 psi)

8.7 Sound pressure

- ≤ 43 dBA ± 2

dBA is measured in free field at a distance of 1 meter from the pump.

8.8 Radio data

Band	Frequency
ISM	2.4 GHz
RF	≤ 2.5 mW (+ 4 dBm)

9 Product Warranty

Commercial warranty

Warranty. For goods sold to commercial buyers, Seller warrants the goods sold to Buyer hereunder (with the exception of membranes, seals, gaskets, elastomer materials, coatings and other "wear parts" or consumables all of which are not warranted except as otherwise provided in the quotation or sales form) will be (i) be built in accordance with the specifications referred to in the quotation or sales form, if such specifications are expressly made a part of this Agreement, and (ii) free from defects in material and workmanship for a period of thirty (30) months from the date of installation or thirty-six (36) months from the date of shipment (which date of shipment shall not be greater than thirty (30) days after receipt of notice that the goods are ready to ship), whichever shall occur first, unless a longer period is specified in the product documentation (the "Warranty").

Except as otherwise required by law, Seller shall, at its option and at no cost to Buyer, either repair or replace any product which fails to conform with the Warranty provided Buyer gives written notice to Seller of any defects in material or workmanship within ten (10) days of the date when any defects or non-conformance are first manifest. Under either repair or replacement option, Seller shall not be obligated to remove or pay for the removal of the defective product or install or pay for the installation of the replaced or repaired product and Buyer shall be responsible for all other costs, including, but not limited to, service costs, shipping fees and expenses. Seller shall have sole discretion as to the method or means of repair or replacement. Buyer's failure to comply with Seller's repair or replacement directions shall terminate Seller's obligations under this Warranty and render the Warranty void. Any parts repaired or replaced under the Warranty are warranted only for the balance of the warranty period on the parts that were repaired or replaced. Seller shall have no warranty obligations to Buyer with respect to any product or parts of a product that have been: (a) repaired by third parties other than Seller or without Seller's written approval; (b) subject to misuse, misapplication, neglect, alteration, accident, or physical damage; (c) used in a manner contrary to Seller's instructions for installation, operation and maintenance; (d) damaged from ordinary wear and tear, corrosion, or chemical attack; (e) damaged due to abnormal conditions, vibration, failure to properly prime, or operation without flow; (f) damaged due to a defective power supply or improper electrical protection; or (g) damaged resulting from the use of accessory equipment not sold or approved by Seller. In any case of products not manufactured by Seller, there is no warranty from Seller; however, Seller will extend to Buyer any warranty received from Seller's supplier of such products.

THE FOREGOING WARRANTY IS EXCLUSIVE AND IN LIEU OF ANY AND ALL OTHER EXPRESS OR IMPLIED WARRANTIES, GUARANTEES, CONDITIONS OR TERMS OF WHATEVER NATURE RELATING TO THE GOODS PROVIDED HEREUNDER, INCLUDING WITHOUT LIMITATION ANY IMPLIED WARRANTIES OF MERCHANTABILITY AND FITNESS FOR A PARTICULAR PURPOSE, WHICH ARE HEREBY EXPRESSLY DISCLAIMED AND EXCLUDED. EXCEPT AS OTHERWISE REQUIRED BY LAW, BUYER'S EXCLUSIVE REMEDY AND SELLER'S AGGREGATE LIABILITY FOR BREACH OF ANY OF THE FOREGOING

WARRANTIES ARE LIMITED TO REPAIRING OR REPLACING THE PRODUCT AND SHALL IN ALL CASES BE LIMITED TO THE AMOUNT PAID BY THE BUYER FOR THE DEFECTIVE PRODUCT. IN NO EVENT SHALL SELLER BE LIABLE FOR ANY OTHER FORM OF DAMAGES, WHETHER DIRECT, INDIRECT, LIQUIDATED, INCIDENTAL, CONSEQUENTIAL, PUNITIVE, EXEMPLARY OR SPECIAL DAMAGES, INCLUDING BUT NOT LIMITED TO LOSS OF PROFIT, LOSS OF ANTICIPATED SAVINGS OR REVENUE, LOSS OF INCOME, LOSS OF BUSINESS, LOSS OF PRODUCTION, LOSS OF OPPORTUNITY OR LOSS OF REPUTATION.

Limited consumer warranty

Warranty. For goods sold for personal, family or household purposes, Seller warrants the goods purchased hereunder (with the exception of membranes, seals, gaskets, elastomer materials, coatings and other "wear parts" or consumables all of which are not warranted except as otherwise provided in the quotation or sales form) will be free from defects in material and workmanship for a period of thirty (30) months from the date of installation or thirty-six (36) months from the product date code, whichever shall occur first, unless a longer period is provided by law or is specified in the product documentation (the "Warranty").

Except as otherwise required by law, Seller shall, at its option and at no cost to Buyer, either repair or replace any product which fails to conform with the Warranty provided Buyer gives written notice to Seller of any defects in material or workmanship within ten (10) days of the date when any defects or non-conformance are first manifest. Under either repair or replacement option, Seller shall not be obligated to remove or pay for the removal of the defective product or install or pay for the installation of the replaced or repaired product and Buyer shall be responsible for all other costs, including, but not limited to, service costs, shipping fees and expenses. Seller shall have sole discretion as to the method or means of repair or replacement. Buyer's failure to comply with Seller's repair or replacement directions shall terminate Seller's obligations under this Warranty and render this Warranty void. Any parts repaired or replaced under the Warranty are warranted only for the balance of the warranty period on the parts that were repaired or replaced. The Warranty is conditioned on Buyer giving written notice to Seller of any defects in material or workmanship of warranted goods within ten (10) days of the date when any defects are first manifest.

Seller shall have no warranty obligations to Buyer with respect to any product or parts of a product that have been: (a) repaired by third parties other than Seller or without Seller's written approval; (b) subject to misuse, misapplication, neglect, alteration, accident, or physical damage; (c) used in a manner contrary to Seller's instructions for installation, operation and maintenance; (d) damaged from ordinary wear and tear, corrosion, or chemical attack; (e) damaged due to abnormal conditions, vibration, failure to properly prime, or operation without flow; (f) damaged due to a defective power supply or improper electrical protection; or (g) damaged resulting from the use of accessory equipment not sold or approved by Seller. In any case of products not manufactured by Seller, there is no warranty from Seller; however, Seller will extend to Buyer any warranty received from Seller's supplier of such products.

THE FOREGOING WARRANTY IS PROVIDED IN PLACE OF ALL OTHER EXPRESS WARRANTIES. ALL IMPLIED WARRANTIES, INCLUDING BUT NOT LIMITED TO THE IMPLIED WARRANTIES OF MERCHANTABILITY AND FITNESS FOR A

PARTICULAR PURPOSE, ARE LIMITED TO THIRTY (30) MONTHS FROM THE DATE OF INSTALLATION OR THIRTY-SIX (36) MONTHS FROM THE PRODUCT DATE CODE , WHICHEVER SHALL OCCUR FIRST. EXCEPT AS OTHERWISE REQUIRED BY LAW, BUYER'S EXCLUSIVE REMEDY AND SELLER'S AGGREGATE LIABILITY FOR BREACH OF ANY OF THE FOREGOING WARRANTIES ARE LIMITED TO REPAIRING OR REPLACING THE PRODUCT AND SHALL IN ALL CASES BE LIMITED TO THE AMOUNT PAID BY THE BUYER FOR THE DEFECTIVE PRODUCT. IN NO EVENT SHALL SELLER BE LIABLE FOR ANY OTHER FORM OF DAMAGES, WHETHER DIRECT, INDIRECT, LIQUIDATED, INCIDENTAL, CONSEQUENTIAL, PUNITIVE, EXEMPLARY OR SPECIAL DAMAGES, INCLUDING BUT NOT LIMITED TO LOSS OF PROFIT, LOSS OF ANTICIPATED SAVINGS OR REVENUE, LOSS OF INCOME, LOSS OF BUSINESS, LOSS OF PRODUCTION, LOSS OF OPPORTUNITY OR LOSS OF REPUTATION.

Some states do not allow limitations on how long an implied warranty lasts, so the above limitation may not apply to you. Some states do not allow the exclusion or limitation of incidental or consequential damages, so the above exclusions may not apply to you. This warranty gives you specific legal rights, and you may also have other rights which may vary from state to state.

To make a warranty claim, check first with the dealer from whom you purchased the product or visit www.xyleminc.com for the name and location of the nearest dealer providing warranty service.

10 Certifications

10.1 FCC 15.247

The 2AYCGXSI01 is compliant to Part 15 of the FCC Rules. Operation is subject to the following two conditions:

1. This device may not cause harmful interference.
2. This device must accept any interference received, including interference that may cause undesired operation.

This device has been designed and complies with the safety requirements for portable (<20cm) RF exposure in accordance with FCC rule part 2.1093 and KDB 447498 D01 as demonstrated in the RF exposure analysis. Installers must ensure that this device must not be co-located or operated in conjunction with any other antenna or transmitter except in accordance with FCC multi-transmitter product procedures.

Unauthorized repairs, changes or modifications could result in permanent damage to the equipment and void your warranty and your authority to operate this device under Part 15 of the FCC Rules.

This equipment has been tested and found to comply with the limits for a Class A digital device, pursuant to part 15 of the FCC Rules. These limits are designed to provide reasonable protection against harmful interference when the equipment is operated in a commercial environment. This equipment generates, uses, and can radiate radio frequency energy and, if not installed and used in accordance with the instruction manual, may cause harmful interference to radio communications. Operation of this equipment in a residential area is likely to cause harmful interference in which case the user will be required to correct the interference at his own expense.

10.2 RSS 102 and RSS-247

The 26881-XSI01 is compliant to RSS 102 and RSS-247

The 26881-XSI01 device complies with the safety requirements for RF exposure in accordance with RSS-102 Issue 5 for portable use conditions.

This device complies with ISSED's license-exempt RSSs. Operation is subject to the following two conditions:

1. This device may not cause harmful interferences.
2. This device must accept any interference received, including interference that may cause undesired operation.

Changes or modifications to this unit not expressly approved by the party responsible for compliance could void the user's authority to operate the equipment.

Xylem |'zīləm|

- 1) The tissue in plants that brings water upward from the roots;
- 2) a leading global water technology company.

We're a global team unified in a common purpose: creating advanced technology solutions to the world's water challenges. Developing new technologies that will improve the way water is used, conserved, and re-used in the future is central to our work. Our products and services move, treat, analyze, monitor and return water to the environment, in public utility, industrial, residential and commercial building services settings. Xylem also provides a leading portfolio of smart metering, network technologies and advanced analytics solutions for water, electric and gas utilities. In more than 150 countries, we have strong, long-standing relationships with customers who know us for our powerful combination of leading product brands and applications expertise with a strong focus on developing comprehensive, sustainable solutions.

For more information on how Xylem can help you, go to www.xylem.com



Xylem Inc.
8200 N. Austin Avenue
Morton Grove IL 60053
Tel: (847) 966-3700
Fax: (847) 965-8379
www.xylem.com/bellgossett

Visit our Web site for the latest version of this document and more information

The original instruction is in English. All non-English instructions are translations of the original instruction.

© 2021 Xylem Inc

Bell & Gossett is a trademark of Xylem Inc or one of its subsidiaries.